

## A Review of Solar Energy in Building Industry

Roohallah Jafari <sup>1,\*</sup>

1- M.Sc. Student, Islamic Azad University, South Tehran Branch, Tehran, Iran

\* Corresponding Author: [Roohi1312rr@gmail.com](mailto:Roohi1312rr@gmail.com)

---

### ABSTRACT

Solar energy sources are the most dominant sources among the renewable energy resources. Electricity from solar energy because it does not increase carbon dioxide emissions production, does not harmful for the environment also PV technologies have nature friendly (Dincer, 2011). More and more energy demand pressures cause the countries to review its economy and energy policies in order to support the sustainable development. Specially in China, the building sector amounts to 27.8% total energy consumption, which is only behind the industry sector. China has abundant solar energy resource, which is extensively applied to buildings. Therefore, solar energy utilization in buildings has become one of the most important issues to help China optimize the energy proportion, increasing energy efficiency and protecting the environment (Li et al, 2007). This article is a review of authoritative articles on solar energy in building industry.

**Key words:** Solar energy; Building industry;

---

### 1. INTRODUCTION

Renewable energy is a sustainable and clean source of energy derived from nature. Renewable energy technology is one of the solutions, which produces energy by transforming natural phenomena (or natural resources) into useful energy forms. Concern about the development of applications of, and the teaching about, renewable energies have increased markedly in recent years (Dincer, 2011). China consumed about 1500 million tons of coal equivalent (MTCE) primary energy in 2002, only behind the US, while China consumed about 1678 MTCE primary energy in 2003 and predicted approximately 2173 MTCE in 2010. Among the total energy consumption, the building sector accounted for 27.8% and it is still

increasing (Crompton and Wu, 2005; Document of the World Bank, 2005). The building sector is the corbel in China and also the second energy consumption terminal to the industry. The building and house industry in China has been experiencing a high-speed growth, and an 11% annual average increment rate was achieved from 1999 to 2004 (MOC, 2002). Solar energy is more and more considered in China as a renewable energy resource compared to conventional energy resources. In the next 5 years following 2005, China will invest 10 billion RMB (1.25 billion US dollars) in developing solar energy photovoltaic application (Li et al, 2007).

It is very important to apply solar energy for a wide variety of applications and provide energy solutions by modifying the energy proportion, improving energy stability, increasing energy sustainability, conversion reduction and hence enhance the system efficiency (Mekhilef et al, 2011). Navarro et al in The educational project involves designing, building and testing a solar energy house connected to the electrical grid with the strategy of maximizing self-consumption, supported by bioclimatic technologies and maintaining a low environmental footprint. It culminates in a on-site contest in which teams must assemble the house themselves, test it with ordinary real life tasks and finally disassemble it. The event has also a divulgative aim, trying to make students and visitors get interested in discovering the problems presented by real engineering and architecture applications. In addition, SDE covers R&D aspects in different fields such as energy efficiency, solar energy and bioclimatic architecture. This article presents the methodology followed during the SDE 2012 edition, in which more than 850 students participated. The obtained results show that the educational competition was a success according to the technical and professional ambitions of the students, most of them considering that their knowledge had increased in areas related to technical and multidisciplinary aspects (Navarro et al, 2014).

## **2. APPLICATION OF SOLAR ENERGY IN BUILDING INDUSTRY IN CHINA**

Currently, solar energy is widely applied directly or indirectly in building industries. Using solar energy in building, industries can lead the communities to create immense environmental and economic benefits. Solar building industries are an inevitable move toward solar technology in the near future. Moreover, customary passive solar thermal systems are moving toward integration of solar material, substances and systems in buildings. Solar energy in building industries was limited in a few applications for several centuries. However, by developing solar technology, it is extensively used as SWHs, solar ventilation, air conditioning systems and photovoltaic power systems (Mekhilef et al, 2011). The main building façade (South oriented) is covered by windows and PV modules by equivalent proportions. This large glazing area (about 46% of the south façade and 12% of building conditioned floor area) interact directly with the office rooms permanently occupied, collecting direct solar energy, providing heat and natural light to these spaces. Increasing the solar heat gains in winter time consisted one of the dominant strategies in the building design, by adopting essential features such as location, size and orientation (south) of the main glazing area (Aelenei et al, 2014).

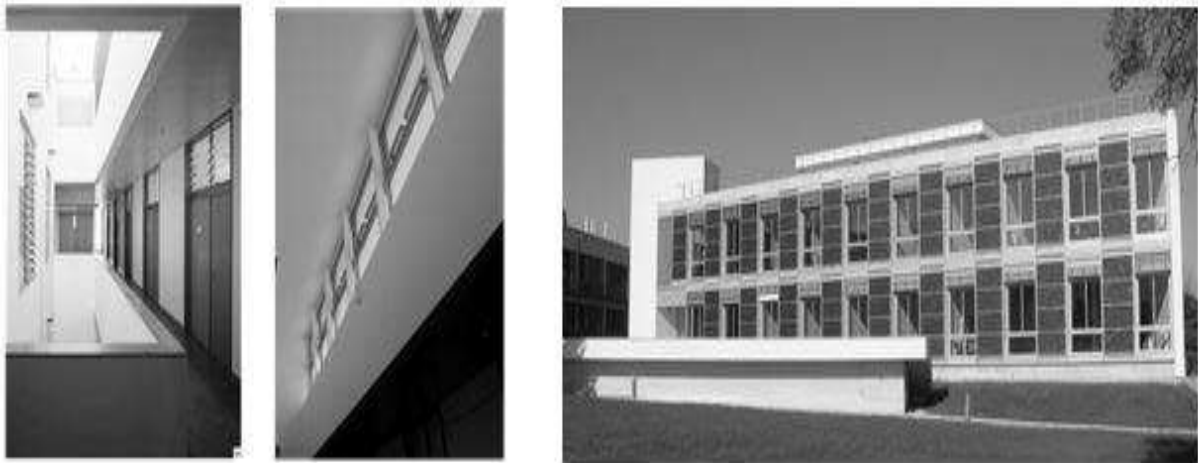

**Fig. 1.** SolarXXI building (interior and exterior views).(Aelenei et al,2014).

Figure 2 illustrates an overview of the *SolarCore* power control architecture. The system is powered by solar energy with grid utility as backup. An automatic transfer switch (ATS) is employed to seamlessly select between the primary (i.e. the solar panel) and backup power sources and an uninterruptable power supply (UPS) ensures continuous power delivery to the load. An AC/DC converter is used only if the ATS switches to the utility. A tunable power-conservative matching network (i.e. DC/DC converter) is used to convert the PV output voltage to the level (e.g. 12V) that is compatible with existing multi-core processors and systems (Li,2011).

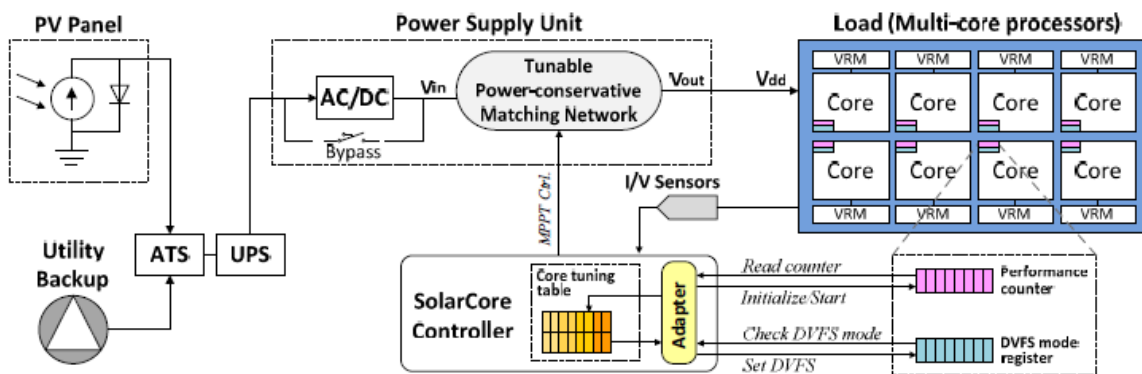

**Fig. 2.** An overview of SolarCore power management architecture (Li, 2011).

In China, the main solar energy uses in building industry involve solar water heater, solar heating buildings, solar refrigeration, air conditioners and photovoltaic system. Especially, with the rapid rise of the energy price, solar energy application in building industry is accelerating.

In China, extensive solar energy utilization in building industry brings great environmental and economic benefits(Xiao et al., 2004; Li et al., 2005; Yin, 2005).

### Solar water heater and hot water system

It is estimated in 2004 that Chinese solar water heater accounted for 30% renewable energy, which was only inferior to mini waterelectricity contribution. At the end of 2005, the annual production capacity of solar water heater thermal collection area rose up to 11 million m<sup>2</sup>. Since 1980, the utilization of solar water heaters has been rapidly expanding with 30% annual average growth rate. By the end of 2001, the total 320-million m<sup>2</sup> solar water collectors had been put into use in China (Yin et al., 2005), and China has become the biggest solar water heater production, sale and holding country in the world.

### Solar heating of buildings

Solar energy is often used to directly heat a house or the building. a solar heating of building includes all kinds of passive and active solar energy utilization technologies, which is commonly integrated with buildings themselves. These technologies involve trombe wall, solar roof and solar greenhouse energy utilization system (ChenBin et al.,2006). Most buildings in China face the south that always receives the strongest sunlight, therefore, the buildings designed for solar heating usually have the large southoriented glass windows or trombe wall or simple solar heated ventilation. When sunlight passes through glass or other glazing, it warms the buildings, and stores solar energy in floors or walls. Proper ventilation allows the heat to circulate within the building(SCI, 1999).



**Fig. 3.** Solar heating of building with trombe wall for natural ventilation(Li et al,2007).

### Building-integration photovoltaic (BIPV) systems

The typical design and integration of photovoltaic cells into the building concerns the wall, rooftop and balcony layout, which replaces conventional building craftwork (Guiavarch and Peuportier, 2006; Wang and Gao 2004; Zhong, 2004). Plenty of BIPV demonstration projects have been completed through international cooperation. Although total power capacity of building integration photovoltaic was only 40,000kW until 2002, which is far laggard compared to the solar heat water application, the development potential is startling. However, the PV industry had startling increment in the recent years, and it is estimated that the annual PV installation capacity in 2005 rose to 300 kiloWatts (kW), and up to 2005, the total completed PV installation capacity rose to a million kW (Li et al, 2007). Photovoltaic energy power systems take place as the most dominant source among renewable energy technologies. The most important reason is that it is unlimited and clean energy of the solar power systems. Many studies show that photovoltaic power systems will have an important share in the electricity of the future (Dincer, 2011).

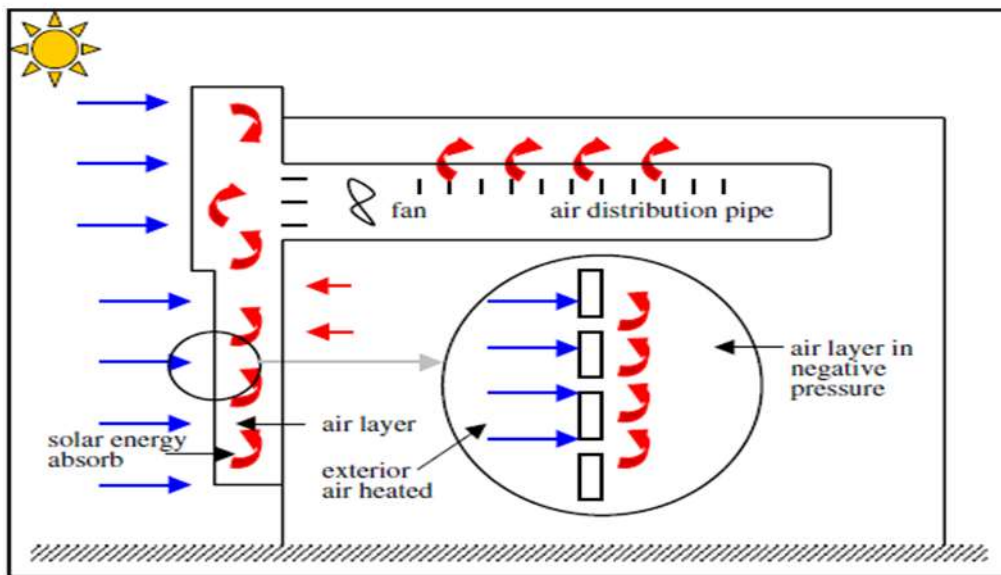

**Fig. 4.** The microstructure of solar wall ventilation responding to Building-integration photovoltaic (BIPV) systems (Li et al, 2007).

### Solar energy refrigeration and air-conditioning

Utilization of solar air-conditioning is the most ideal harmonious state between human and nature, which can create both favorable indoor and outdoor environment temperatures. Therefore, the effect of “warm-island” in the big cities will be cut down. The absorption chiller

driven by solar energy demands no Freon refrigerants, so it does not damage the ozone layer, and is hence named “green airconditioning”. China started solar energy air conditioning development at the end of the 1970s. Plenty of small-scale solar air conditioning samples were tried and experimented since then. Until the “ninth-five plan” period (1996–2001), solar air conditioning application in building industry was mature, and from then on, the ministry of science and technology (MOST) focused on solar air conditioning as a key research item. Many solar air conditioning demonstration projects have been developed to spread its application in buildings till now.



**Fig. 5.** A solar air conditioning system demonstration project in China(Li et al,2007).

### **3. CHINESE SOLAR ENERGY DEVELOPMENT POLICIES IN BUILDING INDUSTRY**

Solar energy development policies in building industry in China can be divided into three administrative levels according to these policies’ feature and influence region. The first level policies are directive and are an outline, and the second are criterion policies. These two level policies are formulated by the central government and operated in the whole nation. These policies involve economic incentive policies, subsidy policies, tax remission policies and tariff favorable polices for solar energy development(Li et al,2007).

The third level policies are idiographic economic incentive policies and administration supervision system, which are usually regulated by local governments. Solar energy policies in China for building industry should involve definite and incentive solar building industry management system and operational mechanisms, such as solar energy technology development, solar energy product generalization, market regulations and its industrialization. Especially, the government should formulate a long-term plan for solar energy application in the buildings, and spread solar energy utilization products to the west of China, which has the most abundant solar energy resources. Furthermore, a systematic solar energy utilization policy

is also indispensable in buildings for reinforcement technology research devotion and international cooperation(Li et al,2007).

#### **4. PROSPECTS OF SOLAR ENERGY IN BUILDING INDUSTRY IN CHINA**

In China, solar energy application in the buildings has experienced three phases. The first solar energy utilization in the building industry is passive sunspace, which simply collects and distributes solar energy through application of buildings orientation, structure and materials. The second stage of solar energy utilization in the building industry shifts to active sunspace. The buildings are heated by solar heating system with solar heat collectors, fans, pumps and radiators, or are refrigerated by solar energy absorption chillers and air-conditioners. The third stage is photovoltaic application to buildings. The solar energy is converted to electric power by the photovoltaic system installed in building's, which fully meets the building's operation energy demands for heating, lighting, ventilation and air-conditioning, and even to so-called "zero energy consumption building"(Li et al,2007). Renovation is one of the main tasks in the building sector and will have a major impact for global sustainability. Because renovation conserves the building status for the following decades, energy saving measures should be an inherent part of it. The combination of renovation and improvement of energy efficiency is technologically and economically significantly more attractive than separate measure(Voss,2000).

#### **5. CONCLUSIONS**

Solar energy is a clean and inexhaustible resource and compatible to application in the building industry. China has abundant solar energy, which is extensively by utilized in the building industry in terms of solar water heater, solar heating and cooling of buildings and photovoltaic power production. With the rapid economic development and monetary housing policy implementation, China has been experiencing a high growth in the building industry, and it can be predicted that the total urban housing and public building area will be further booming due to the rapid industrialization and urbanization in the future(Li et al,2007). The bottleneck of energy saving buildings, especially for solar energy building development, is not the lack of solar energy technology and the shortage of environment protection intentions, but the shortage of national economic incentive mechanisms on the basis of benefits. The breakthrough of application and prospects of solar energy in the building industry in China is dependent on establishment of nationwide economic incentive mechanisms including tax, financial, subsidy and tariff policies. In addition, the uniform technology standards and criteria are expected to aid the promotion of solar energy application to building industry(Li et al,2007). Presently, solar energy conversion is widely used to generate heat and produce electricity. A comparative study on the world energy consumption released by International Energy Agency (IEA) shows that in 2050, solar array installations will supply around 45% of energy demand in the world. It was found that solar thermal is getting remarkable popularity

in industrial applications. Solar thermal is an alternative to generate electricity, process chemicals or even space heating. It can be used in food, non-metallic, textile, building, chemical or even business related industries. On the other hand, solar electricity is widely applied in telecommunication, agricultural, water desalination and building industry to operate lights, pumps, engines, fans, refrigerators and water heaters(Mekhilef et al).

## REFERENCES

- (1) Aeleneia, Laura and Helder Gonçalves(2014). From solar building design to Net Zero Energy Buildings:performance insights of an office building. SHC 2013, International Conference on Solar Heating and Cooling for Buildings and Industry September 23-25, 2013, Freiburg, Germany. Energy Procedia 48 ( 2014 ) 1236 – 1243.
- (2) Chen, Bin, Meng, S., Chen, H., et al., 2006. Effect of advanced trombe walls on indoor environment moisture control. Heating Ventilating & Air Conditioning 36 (3), 42–46.
- (3) Crompton, P., Wu, Y., 2005. Energy consumption in China: past trends and future directions. Energy Economics 27, 195–208.
- (4) Dincer ,furkan(2011). The analysis on photovoltaic electricity generation status, potential and policies of the leading countries in solar energy Renewable and Sustainable Energy Reviews. Published by Elsevier Ltd.
- (5) Guiavarch, A., Peupartier, B., 2006. Photovoltaic collectors efficiency according to their integration in buildings. Solar Energy 80 (1).65–77.
- (6) Li,chao, Wangyuan Zhang, Chang-Burm Cho and Tao Li(2011). **SolarCore: Solar Energy Driven Multi-core Architecture Power Management**. 978-1-4244-9435-4/11/\$26.00 ©2011 IEEE.
- (7) S. Mekhilefa,\*, R. Saidurb, A. Safari(2011). A review on solar energy use in industries. Renewable and Sustainable Energy Reviews15 (2011) 1777–1790 . Elsevier Ltd.
- (8) MOC, 2002. Outline of the 10th Five Plan of Building Energy Efficiency of MOC, (In Chinese).
- (9) Navarro, Álvaro Gutiérreza, Claudio Montero, Edwin Rodríguez-Ubiñas(2014). Experiences and methodology in a multidisciplinary energy and architecture competition: Solar Decathlon Europe2012, Energy and Buildings, Elsevier B.V.
- (10) Solar Center Information (SCI), 1999. Passive Solar Options For NorthCarolina Homes.
- (11) Voss,Karsten(2000). Solar energy in building renovation-results and experience of international demonstration buildings. Energy and Buildings 32 \_2000. 291–302



- (12) Xiao, C., Luo, H., Tang, R., 2004. Solar thermal utilization in China. *Renewable Energy* 29, 1549–1556.
- (13) Yin, Z., 2005. Development of solar thermal systems in China. *Solar Energy Materials & Solar Cells* 86, 427–442.
- (14) Zhi-Sheng Lia, b, \_, Guo-Qiang Zhangb, Dong-Mei Lia, Jin Zhoub, Li-Juan Lia, Li-Xin Li(2007), Application and development of solar energy in building industry and its prospects in China.